

# GN 923.7

Solid handwheels with safety fold-away handle

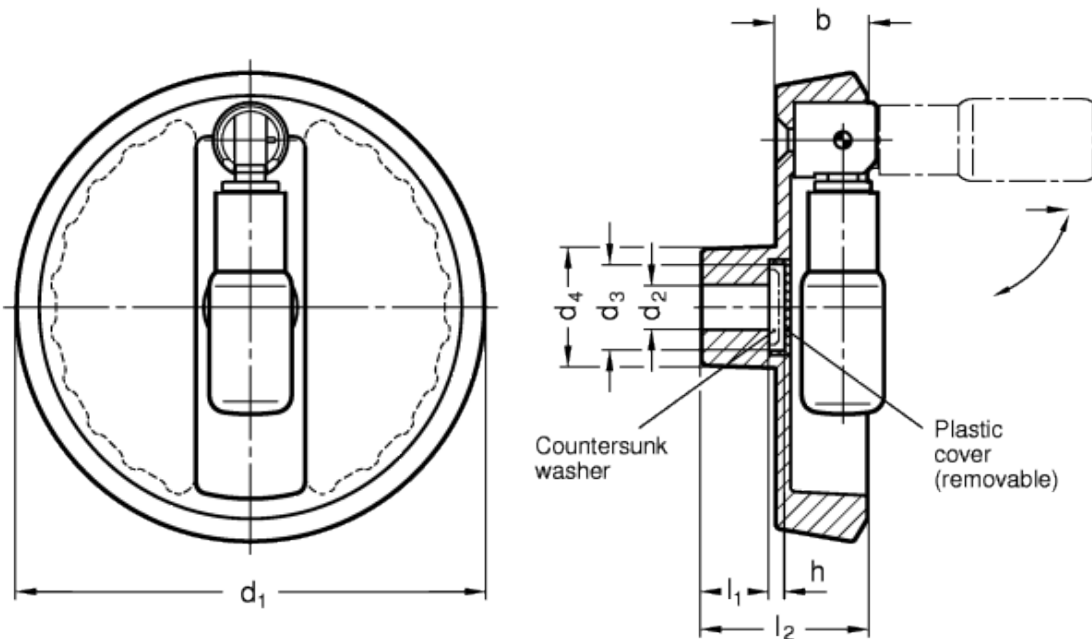

## technical informations

### Material

Aluminium pressure die casting, hub machined, rim turned.  
Type R: with revolving handle.

### Colour

- Version SW: plastic coated, black RAL 9005, textured finish.
- Version SR: plastic coated, silver RAL 9006, textured finish.

### Assembly

- Version B: hub with H7 tolerance plain hole.
  - Version K: hub with H7 reamed hole with keyway in compliance with [DIN 6885/1 P9 tolerance](#).
- For fixing GN 923.7 on shafts by a grub screw see [Technical Data](#).

### Plastic cover

Polyamide based (PA) technopolymer, light-grey colour, push-fit assembly.

### Fold-away handle

Type GN 798.7 in polyamide based (PA) technopolymer, black colour, matte finish. Resistant to solvents, oils, greases and other chemical agents. The two-volume special design of the handle provides the operator's hand with a safe and ergonomic grip when turning the handwheel.

### Accessories on request

Axial retaining washer [GN 184](#).

### Features and applications

Solid handwheels GN 923.7 with safety fold-away handle are distinguished by modern design. These handwheels are suitable for applications where the handle must not remain in the operation position. In order to bring the handle into this position it has to be turned first through 90° to a stop against a torsion spring and then it is pushed against spring pressure into its hold position. By maintaining the forward thrust on the handle the handwheel can easily be rotated. When releasing the handle the springs returns it back to the retracted position.

### Technical data

Axial and radial runout lower than 0.4.

Standard Elements	Main dimensions						Bore		Handle	Recommended washer	Weight
Description	d <sub>1</sub>	d <sub>3</sub>	d <sub>4</sub>	b	h	l <sub>2</sub>	d <sub>2H7</sub>	l <sub>1</sub>	Ø		g
GN 923.7-125-B12-R-*	125	23	31	24.5	4	45	12	18	22	GN 184-22	450
GN 923.7-125-K12-R-*	125	23	31	24.5	4	45	12	18	22	GN 184-22	440
GN 923.7-125-B14-R-*	125	23	31	24.5	4	45	14	18	22	GN 184-22	440
GN 923.7-125-K14-R-*	125	23	31	24.5	4	45	14	18	22	GN 184-22	430
GN 923.7-140-B14-R-*	140	23	36	26	4	47	14	19	24	GN 184-22	590
GN 923.7-140-K14-R-*	140	23	36	26	4	47	14	19	24	GN 184-22	585
GN 923.7-140-B16-R-*	140	23	36	26	4	47	16	19	24	GN 184-22	590
GN 923.7-140-K16-R-*	140	23	36	26	4	47	16	19	24	GN 184-22	585
GN 923.7-160-B14-R-*	160	23	36	26	4	48	14	20	24	GN 184-22	760
GN 923.7-160-K14-R-*	160	23	36	26	4	48	14	20	24	GN 184-22	750
GN 923.7-160-B16-R-*	160	23	36	26	4	48	16	20	24	GN 184-22	760
GN 923.7-160-K16-R-*	160	23	36	26	4	48	16	20	24	GN 184-22	750
GN 923.7-200-B18-R-*	200	23	42	27	4	53	18	24	25	GN 184-22	1100
GN 923.7-200-K18-R-*	200	23	42	27	4	53	18	24	25	GN 184-22	1090
GN 923.7-200-B20-R-*	200	23	42	27	4	53	20	24	25	GN 184-22	1100
GN 923.7-200-K20-R-*	200	23	42	27	4	53	20	24	25	GN 184-22	1090

\* Complete the description of the standard item needed by adding the colour of the handwheel: SW (black) or SR (silver).

This product had the following design awards:



reddot design award  
winner 2010



STANDARD MACHINE ELEMENTS WORLDWIDE